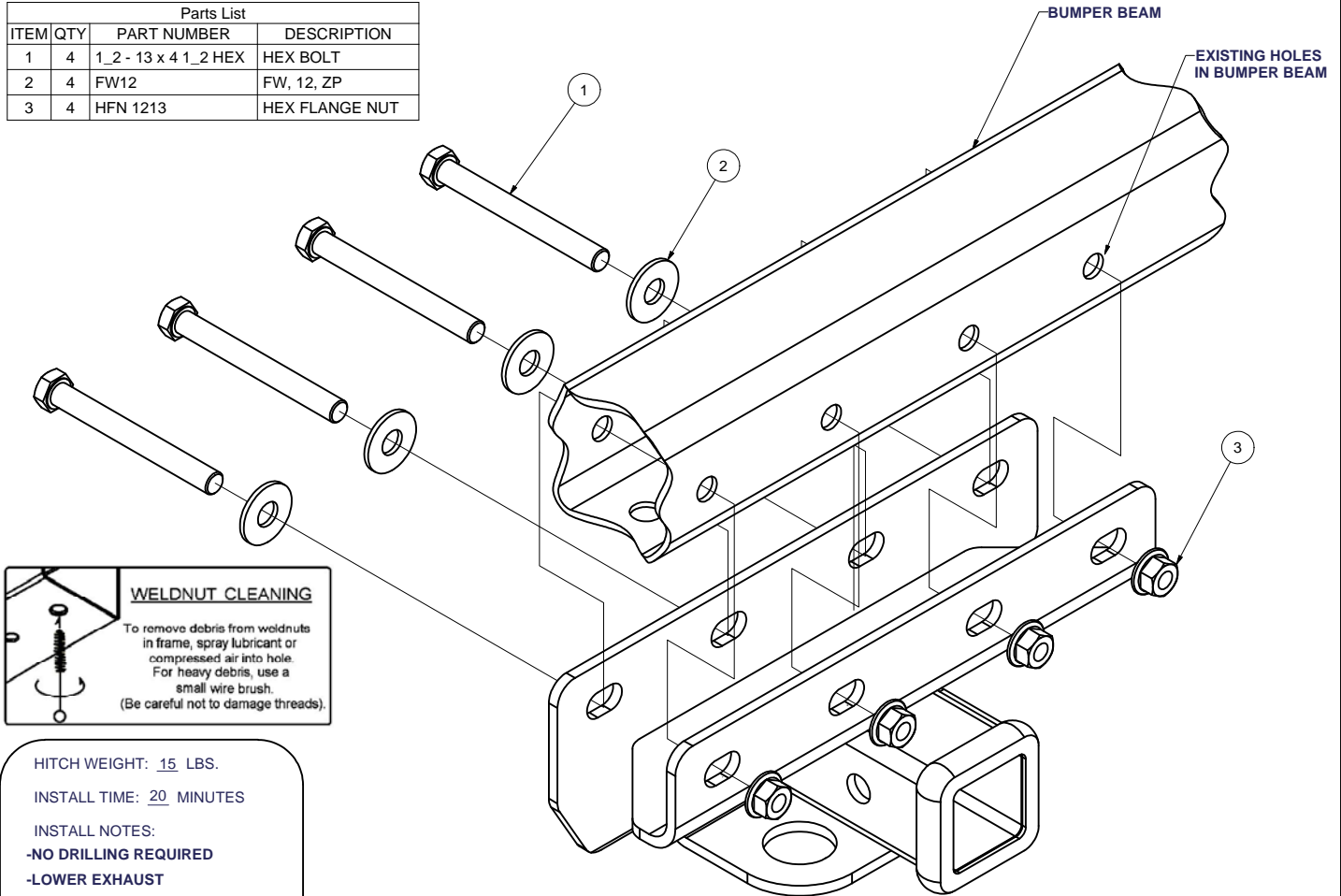

ENT23431**JEEP WRANGLER 2-DOOR/4-DOOR
&
RUBICON X / 10TH Anniversary****12/29/14**

**GROSS LOAD CAPACITY WHEN USED AS A WEIGHT CARRYING HITCH: 3500 LBS. TRAILER WEIGHT & 350 LBS. TONGUE WEIGHT.
GROSS LOAD CAPACITY WHEN USED AS A WEIGHT DISTRIBUTION HITCH: 4000 LBS. TRAILER WEIGHT & 400 LBS. TONGUE WEIGHT**
DO NOT EXCEED VEHICLE MANUFACTURER'S RECOMMENDED TOWING CAPACITY.

Parts List			
ITEM	QTY	PART NUMBER	DESCRIPTION
1	4	1_2 - 13 x 4 1_2 HEX	HEX BOLT
2	4	FW12	FW, 12, ZP
3	4	HFN 1213	HEX FLANGE NUT

HITCH WEIGHT: 15 LBS.INSTALL TIME: 20 MINUTES

INSTALL NOTES:

- NO DRILLING REQUIRED
- LOWER EXHAUST
- MAY REQUIRE HOLE ENLARGMENT

INSTALLATION STEPS

- 1) Detach the muffler from the rubber muffler hanger and lower the exhaust for ease of installation.
- 2) Position the hitch over the bumper beam and align the holes of the hitch with holes in the cross member. When the hitch is properly positioned, the hitch will be centered in the existing rectangular cutout at the bottom of the bumper fascia.

For Rubicon X & 10th Anniversary models remove factory (4) M12 bolts and spacer plate, retain hardware for later use and return plate to owner. Clean weldnuts if needed. See (WELDNUT DIAGRAM)

- 3) Insert fasteners as shown making sure the flange nuts are installed on the exterior side of the hitch. Some models may require hole enlargement.

For Rubicon X & 10th Anniversary models reinstall factory hardware.

- 4) Torque all 1/2" fasteners to 110 lb-ft.
Torque M12 bolts to 120 lb-ft.

PERIODICALLY CHECK THIS RECEIVER HITCH TO ENSURE THAT ALL FASTENERS ARE TIGHT AND THAT ALL STRUCTURAL COMPONENTS ARE SOUND.

ENTHUZE™ warrants this product to be free of defects in material and/or workmanship at the time of retail purchase by the original purchaser. If the product is found to be defective, ENTHUZE™ may repair or replace the product, at their option, when the product is returned, prepaid, with proof of purchase. Alteration to, misuse of, or improper installation of this product voids the warranty. ENTHUZE™ liability is limited to repair or replacement of products found to be defective, and specifically excludes liability for incidental or consequential loss or damage.